



Part-turn gearboxes

Worm gearboxes

GS 50.3 – GS 250.3

GS 315 – GS 500

Torques up to 360,000 Nm

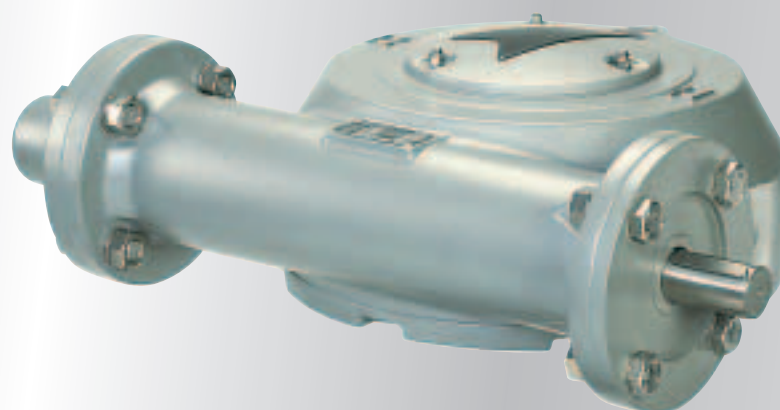



Applications

AUMA part-turn gearboxes are used wherever the operation of part-turn valves is required, e.g. butterflyvalves or ball valves. They are suitable for both manually operated and motor driven valves.

Due to their wide torque range, their modular design and potential for use in combination with electric multi-turn actuators, the gearboxes can be used for the most varied applications.



Power

- : Conventional power plants (coal, gas, oil)
- : Hydroelectric power plants
- : Geothermal power plants
- : Solar thermal power plants
- : Biogas power plants



Water sector

- : Sewage treatment plants
- : Water treatment plants
- : Drinking water distribution
- : Seawater desalination
- : Steel construction for water resources



Oil & gas

- : Exploration, offshore plants
- : Refineries
- : Distribution
- : Gas tanks
- : Tank farms



Industrial and special solutions:

- : Air conditioning
- : Food industry
- : Chemical/pharmaceutical industry
- : Vessel and submarine shipbuilding
- : Steel mills
- : Paper industry
- : Cement works
- : Mining

Table of contents	
Modular design/versions	4
Summary of applications, functions, and equipment	6
Design principle	7
Service conditions	8
Functions	10
Signals	13
Indications	14
Valve attachment	15
Technical data	16
Certificates	18
Literature	20
Index	21
AUMA worldwide	22

Solutions for a world in motion

This brochure will provide both the beginner and the expert with an overview of the functions and applications of AUMA GS part-turn gearboxes. It can be used as the basis to determine whether a device is suitable for the chosen application.

For detailed product selection refer to the separate data sheets, dimension sheets and price lists. On request, AUMA engineers within field service and within our subsidiaries can help you find the correct device for the application.

AUMA's first generation of GS part-turn gearboxes was introduced in 1967. Ever since the gearboxes have been continuously improved; two features, however, remain unchanged:

- a simple and robust design principle
- high end stop strength.

A long lifetime with very low maintenance, even under high loads, are the benefits of this sophisticated gearbox range.

The latest detailed information on the GS part-turn gearboxes can be found on the Internet under www.auma.com. All documents, including dimensional drawings, and final inspection records for supplied gearboxes are available on the Internet in digital form.

Subject to change without notice.

The product features and technical data provided do not express or imply any warranty.

Modular design/versions

Modular concept – manual or motor operation

Valves are available in many designs and different sizes. Depending on the application, butterfly valves, ball valves or dampers with diameters ranging from a few centimetres to several metres are to be opened or closed and controlled either manually or electrically.

AUMA meets the various requirements with their modular product range. A key element is the GS part-turn gearbox type range that can be adapted to various valve requirements. Furthermore it can be combined with other AUMA products which expands its wide range of various applications.

Manual drive

From a certain valve size on, a gearbox is required to operate part-turn valves manually. The reduction ratio within the gearing reduces the required input torques. Additional primary reduction gearings and handwheels with various diameters allow adapting the gearboxes to your particular requirements.

Motor operation

By combining a GS part-turn gearbox with an AUMA multi-turn actuator from the SA range you obtain an electric part-turn actuator. Part-turn valves with high torque requirements can be automated by using these combinations. The largest combinations provide torques up to 360,000 Nm.

SA multi-turn actuators are also available in explosion-proof version. The GS gearboxes are therefore approved for the installation in potentially explosive atmospheres in accordance with ATEX.

- Product description Multi-turn actuators for OPEN - CLOSE and modulating duty

Shutting off, positioning, controlling

The duty type is an important selection condition for gearboxes used in combination with a multi-turn actuator. Is the valve to be used as shut-off device (open-close duty) or is the valve to be positioned in mid-travel (positioning mode) or is the valve a control valve where the valve position is to be changed at short intervals, i.e. to control the flow rate through a pipeline (modulating duty)? These are essential factors for sizing the valve, but also for actuator and gearbox as the load may vary considerably depending on the operation mode.

AUMA GS part-turn gearboxes are suitable for all types of duty. Gearboxes which are to be used for modulating duty need a worm wheel made of bronze instead of the standard worm wheel made of spheroidal cast iron.

Versions

There are clockwise and counterclockwise closing valves; both versions can be used within a single plant. However a uniform closing direction within the entire plant is required. For this reason GS gearboxes are available as clockwise closing and counterclockwise closing versions. For example, you close a counterclockwise closing valve with a clockwise rotation at the handwheel.

To be able to consider the different mounting positions in your installation, we offer gearboxes with input shafts either on the left side or the right side.

In total, there are four versions.

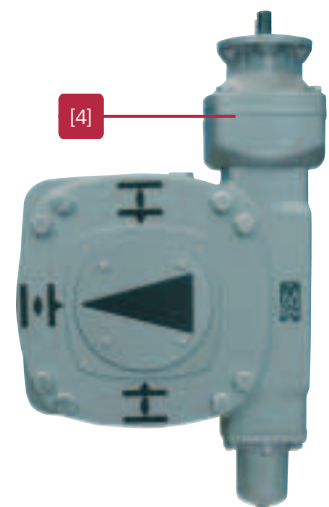

[1] Worm gearboxes GS

with handwheel for manual operation of a valve

[2] Part-turn actuator as SA/GS combination

Torques up to 360,000 Nm.

Combining an SA multi-turn actuator with a GS worm gearbox results in a part-turn actuator. Contrary to the version for manual operation, the input of the worm gearbox includes an actuator mounting flange. The multi-turn actuator is mounted with a screw connection to the gearbox which can easily be removed for maintenance purposes. The flange connection between multi-turn actuator meets the requirements of EN ISO 5210 or DIN 3210 as an alternative.

[3] Worm gearbox versions

The first letter in the version designation indicates the position of the input shaft with regard to the worm wheel, the second letter the direction of rotation of the gearbox output. RR, for example, means an input shaft on the right, for clockwise rotation at the gearbox input, the direction of rotation at the output is the same as at the gearbox input. LL, on the other hand, means an input shaft on the left, the direction of rotation at the input is reversed at the gearbox output.

[4] Worm gearbox with primary reduction gearing

The primary reduction gearing is mounted at the gearbox input. This enables to further reduce the required input torques and to operate relatively large valves manually. For motor-operated applications, a rather small and more cost-effective multi-turn actuator can be combined with a large worm gearbox using a primary reduction gearing. It has to be verified whether the increased operating time caused by the additional reduction is acceptable.

Summary of applications, functions, and equipment

Standard ● Option ■	GS 50.3 – GS 250.3	GS 315 – GS 500	Page
Applications/duty types			
Manual operation	●	●	4
Motor operation	■	■	4
Open-close duty	■	■	4
Positioning duty	■	■	4
Modulating duty	■	■	4
Service conditions			
Enclosure protection IP 67	–	●	8
Enclosure protection IP 68-3	●	–	8
Enclosure protection IP 68, IP 68-6, IP 68-10, IP 68-20	■	■	8
Version for buried service	■	■	8
High temperature version	■	■	8
Low temperature version	■	■	8
Corrosion protection KN	●	●	9
Corrosion protection KS, KX	■	■	9
Explosion protection	■	■	9
Functions			
Limitation of the swing angle	●	●	10
Simple and precise setting of the end positions	■	●	11
High safety against fracture	●	●	6
Protection against accidental changing of the valve position	■	■	12
Feedback signals			
Valve end positions	■	■	13
Valve position	■	■	13
Local indication			
Valve end positions	●	●	14
Valve position	●	●	14
Valve is running	●	●	14
Valve attachment according to EN ISO 5211			
Coupling unbored	●	●	15
Extended coupling	■	■	15
Coupling with bore	■	■	15

Design principle

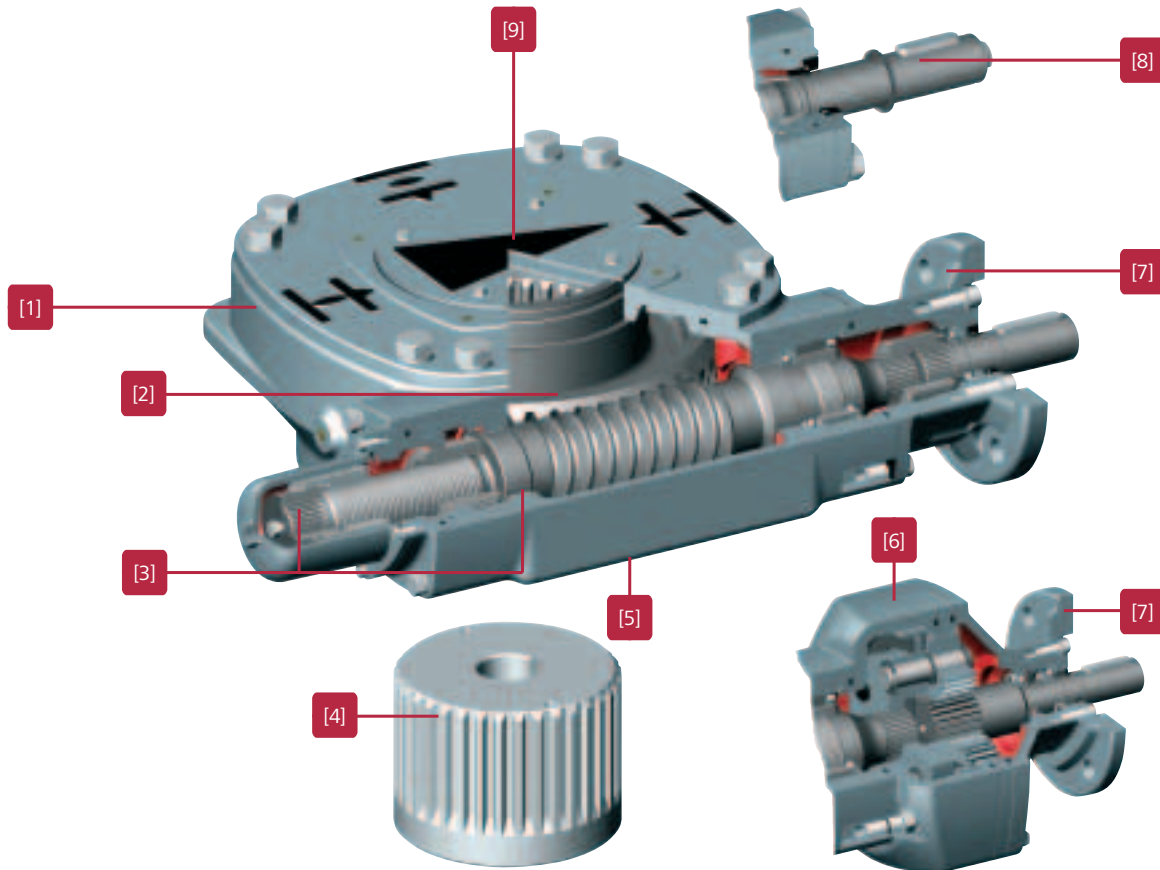

[1] Housing

In its basic version, the housing is made of cast iron. A housing made of spheroidal cast iron can be used if it is likely to be exposed to extreme external loads, e.g. in seismic areas.

[2] Gearing

Principal item is the worm gearing enabling a high reduction ratio within a single stage. In the basic version the worm wheel is made of spheroidal cast iron. As an option the worm wheel is also available made of bronze which is used for control valves.

[3] End stops

The internal end stops limit the swing angle. The significant advantage of the AUMA design: Only the comparatively low input torque acts on the end stops, not the high output torque. Thereby a high level of safety against damage due to overload is assured.

[4] Coupling

The separate coupling enables easier mounting of the gearbox to the valve. On request, the coupling is supplied with a suitable hole. The coupling with bore is placed on the valve shaft and secured against axial movement. Subsequently the gearbox is fitted on the valve flange (refer also to page 15).

[5] Valve attachment

The valve attachment is designed according to EN ISO 5211. The gearbox can be positioned on the valve at every 90°.

[6] Reduction gearing

The primary reduction gearing utilises planetary gears or spur gears to reduce the required input torque. They can be used for manually operated and motor-operated gearboxes.

[7] Flange for mounting a multi-turn actuator

The flange sizes are according to EN ISO 5210 (optional DIN 3210).

[8] Input shaft for manual operation

For gearboxes that are operated manually, a handwheel is fitted onto the input shaft. The handwheels are available with various diameters.

[9] Pointer cover

Gearboxes up to enclosure protection IP 68-6 can be supplied with a pointer cover. The pointer cover follows the travel, continuously showing the valve position and can also be used as running indication. For high enclosure protection versions, we recommend replacing the pointer cover with a protection cover. As an option, sealed pointer covers are available for high enclosure protection versions or for horizontal outdoor installation.

Service conditions

AUMA devices are used worldwide; in all climate zones, in industrial plants of all kinds under special local ambient conditions. AUMA devices have to operate reliably and for a long time under any conditions without requiring major maintenance work. For this very reason, AUMA has focussed on making AUMA devices resistant to the most unfavourable conditions and have adapted their protective measures to the state-of-the-art technology.



AUMA gearboxes work reliably in all climate zones worldwide and under extreme local conditions.

Enclosure protection

IP 67

The worm gearboxes of the type range GS 315 – GS 500 according to EN 60 529 with pointer cover for position indication conform in the basic version to enclosure protection IP 67.

IP 68-3

The worm gearboxes GS 50.3 – GS 250.3 conform to enclosure protection IP 68-3 according to EN 60 529. The gearboxes are dust and water tight up to a maximum of 3 m head of water.

IP 68-6 or IP 68, IP 68-10 or IP 68-20¹

On request, the devices are available with increased enclosure protection IP 68, IP 68-6, IP 68-10 and IP 68-20 according to EN 60 529. The gearboxes are dust and water tight up to a maximum of 6 m, 10 m, or 20 m head of water.

Buried service

The gearboxes are suitable for buried service if they are equipped with a protection cover instead of a pointer cover.

Depending on the application, additional corrosion protective measures may be required.

¹ For size GS 50.3, maximum enclosure protection IP 68-3

Ambient temperatures

Versions	Temperature range ¹
Standard	– 40 °C ... + 60 °C
Options	0 °C ... + 120 °C ² – 50 °C ... + 60 °C – 60 °C ... + 60 °C

¹ If a gearbox is used in combination with a multi-turn actuator, observe the admissible temperature range of the multi-turn actuator.

² For the remote mounted position transmitter WSG 90.1 or WGD 90.1 with electronic position transmitter the maximum permissible ambient temperature is + 70 °C.

Corrosion protection/colour

Standard (KN)

The standard AUMA corrosion protection KN is a high quality coating. This is suitable for outdoor installation and for slightly aggressive atmospheres with a low level of pollution.

KS

AUMA recommends this corrosion protection class for installation in occasionally or permanently aggressive atmospheres with a moderate pollutant concentration.

KX

AUMA recommends this corrosion protection class for installation in aggressive atmosphere with high humidity and a high pollutant concentration.

Colour

The standard colour of the finish coating is silver-grey (similar to RAL 7037). Other colours are available on request.

In their basic version, gearboxes GS 160.3 and above are only supplied with primer coating. A finish coating is available on request.



For an irrigation project in Malaysia large multi-turn GS gearboxes without end stops are used. The illustrated plant shows how the position of the weir penstock is controlled.

Explosion protection

For the installation of valve gearboxes in potentially explosive atmospheres, special protective measures are required.

AUMA gearboxes are approved for installation in potentially explosive zones.

They comply with the regulations stipulated in European standard EN 13463-1 et seqq. AUMA certifies this in a declaration of incorporation.

Classification of explosion protection

- II2G c IIC T4 according to ATEX 94/9/EC



A very special solution. Two series-connected GS gearboxes are operated via one common multi-turn actuator to change the setting of a dual butterfly valve synchronously.

Functions

The basic function of the GS part-turn gearboxes is to decrease the input torque required at the valve by means of a reduction ratio. Further marginal conditions must be observed, e.g. static self-locking of the manual gearbox is often required.

It is expected that the gearbox will function over a long period of time and in all climatic conditions. Furthermore installation and commissioning should be easy and the maintenance requirements low. The high demands on availability and ease of maintenance can only be met by a sophisticated design. The GS gearbox range is an excellent example of this.



GS 500 gearboxes with primary reduction gearing and with SA multi-turn actuators in a desulphurisation unit of an Australian power plant.

Limitation of the swing angle

In general the end stops limit the swing angle within the valve. However, there are valves that do not have any internal end stops, e.g. ball valves.

If such a valve is operated manually, it can be positioned precisely in the end position by approaching the end stops of the GS gearbox. This is particularly important if the position indication at the valve or the gearbox is not visible.

For motor-operated valves the actuator is equipped with limit switching which trips the actuator when reaching the end position, before reaching the end stop. During commissioning the end stops should be set shortly after the switching points of the limit switching. The end stops are used for safety reasons if the limit switching fails.

Swing angle ranges

Most part-turn valves require a 90° movement for covering the travel from OPEN to CLOSED. Some valves require other swing angles. For this reason, the GS gearboxes have different swing angle ranges.

Gearboxes	Swing angle ranges	Comment
GS 50.3 – GS 125.3	Standard 80° – 100° Options 10° – 35°, 35° – 60°, 60° – 80°, 100° – 125°, 125° – 150°, 150° – 170°, 170° – 190° > 190°: multi-turn version, without end stops	Standard Swing angle is set in the factory and cannot be changed. Option Swing angle adjustable within the ranges indicated
GS 160.3 – GS 250.3	Standard 80° – 100° Options 20° – 40°, 40° – 60°, 60° – 80° > 100°: multi-turn version, without end stops	Swing angle adjustable within the ranges indicated
GS 315 – GS 500	Standard 0° – 135° Option > 135°: multi-turn version, without end stops	Swing angle adjustable within the ranges indicated

Simple and precise setting of the end positions

Setting an end position

The swing angle of the gearbox is generally set in the factory to the swing angle required on site, i.e. the swing angle between valve position OPEN and CLOSED may not be changed. During commissioning, only one end stop has to be set; the other end stop will automatically be set via the preset swing angle.

Changing the swing angle

Only if the swing angle set in the factory is not correct and has to be adjusted, have the two end positions to be set separately. This is not possible in the basic version for gearbox sizes GS 50.3 – GS 125.3.

High safety against fracture

Due to the special AUMA design, the gearboxes have a high end stop strength, which is several times the maximum input torque. For motor operation, excessive input torques are avoided by the overload protection function within the actuator. Extreme input torques can occur during manual operation, if e.g. the operator operates the valve with a large T-wrench.

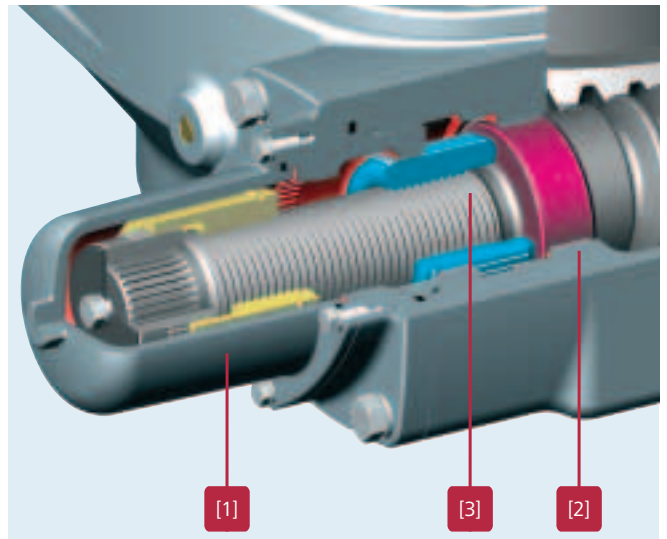

End stops for sizes GS 160.3 – GS 250.3. This design enables the swing angle to be changed at a later date.

[1] **End stop OPEN (yellow)**

[2] **End stop CLOSED (violet)**

[3] **Travelling nut (blue)**

The travelling nut moves back and forth on a thread between the two end stops. Only the comparatively low input torque acts on the end stops, not the high output torque. The forces are contained in the end stop and the worm shaft, the housing is not affected. Should an end stop break due to extreme overload, the housing is not damaged and the gearbox can be repaired.

Functions

Protection against accidental changing of the valve position

Gravity, vibrations or forces acting upon the medium within a pipeline may lead to accidental changes in the valve position. This has to be prevented.

Self-locking

Due to their design, the valve gearboxes counteract torques acting upon the output side with a load. If the load prevents the valve position from being changed from standstill, this is called self-locking.

The gearboxes are self-locking when at standstill under normal service conditions; strong vibrations may cancel the self-locking effect. Self-locking can be achieved by mounting an anti-backdrive device.

Self-braking

If the valve is effectively brought to a standstill after operation, this is called self-braking. The braking torque of the actuator has to correspond to at least the maximum output torque.

This requirement can also be met by using an anti-backdrive device.

Anti-backdrive device

By using an LMS 07.1 – LMS 16.1 anti-backdrive device, both self-locking and self-braking can be achieved. The retaining or braking torque of the combination between anti-backdrive device and gearbox corresponds to at least the maximum output torque of the gearbox..

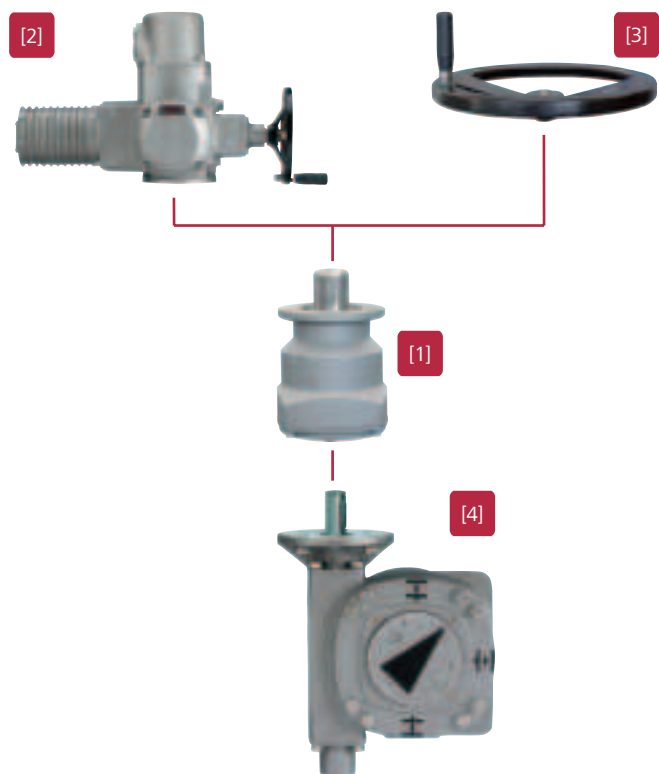

The anti-backdrive device [1] can be used for motor-operated and manually operated valves. Therefore a multi-turn actuator [2] or a hand-wheel [3] is mounted at the input flange of the anti-backdrive device.

Apart from small sizes, the anti-backdrive device is mounted at the input flange of the worm gearbox [4]. Only the comparatively low input torque acts on the anti-backdrive device, not the high output torque. Consequently, the braking effect of the anti-backdrive device is amplified by the amount of the reduction ratio of the gearbox.

Signals

Signals are the foundation for controlling a process flow. Manually operated valves can also provide feedback signals if equipped accordingly.

For gearboxes used in combination with a multi-turn actuator, the actuator generally performs the task of supplying the DCS with the required feedback signals.

Feedback signals

In order to provide a DCS with information on the valve position, the manually operated worm gearbox can be equipped with a valve position indicator WSG 90.1 or WGD 90.1. WSG 90.1 is used for gearboxes with a swing angle of less than 180°, WGD 90.1 for larger swing angles.

WSG 90.1 or WGD 90.1 are mounted instead of a pointer cover. As a substitute, the valve position indicators are equipped with a position indicator.

Valve end position

The integral end position switches signal that a valve end position has been reached.

Valve position

An optional position transmitter provides the DCS with the valve position either as a voltage signal or as a 0/4 – 20 mA current signal.



Multi-turn actuator/worm gearbox combination in a water treatment plant in Australia.

Indication

Depending on the installed location it is not always possible to identify the valve position on site. Many applications require that the valve position is displayed locally.

Local indication

In the basic version, the gearboxes are provided with a pointer cover, providing the following information.

Valve end position

The end position symbols indicate that an end position has been reached.

Valve position

Via the pointer position you may estimate the valve position.

Valve is running

The pointer cover is coupled directly to the worm wheel and therefore to the valve shaft. Any valve operation is reliably indicated.



Valve attachment

The gearbox is mounted to the valve using a mounting flange standardised according to EN ISO 5211.

The torque is transmitted to the valve shaft via a separate coupling. In the basic version, the coupling is unbored or from certain sizes available with pilot bores; it may also be provided with the bores shown below.

In case of special valve designs with a low valve stem or if an intermediate flange is required between gearbox and valve, the coupling might be too short. For such cases, the coupling is also available in an extended version.

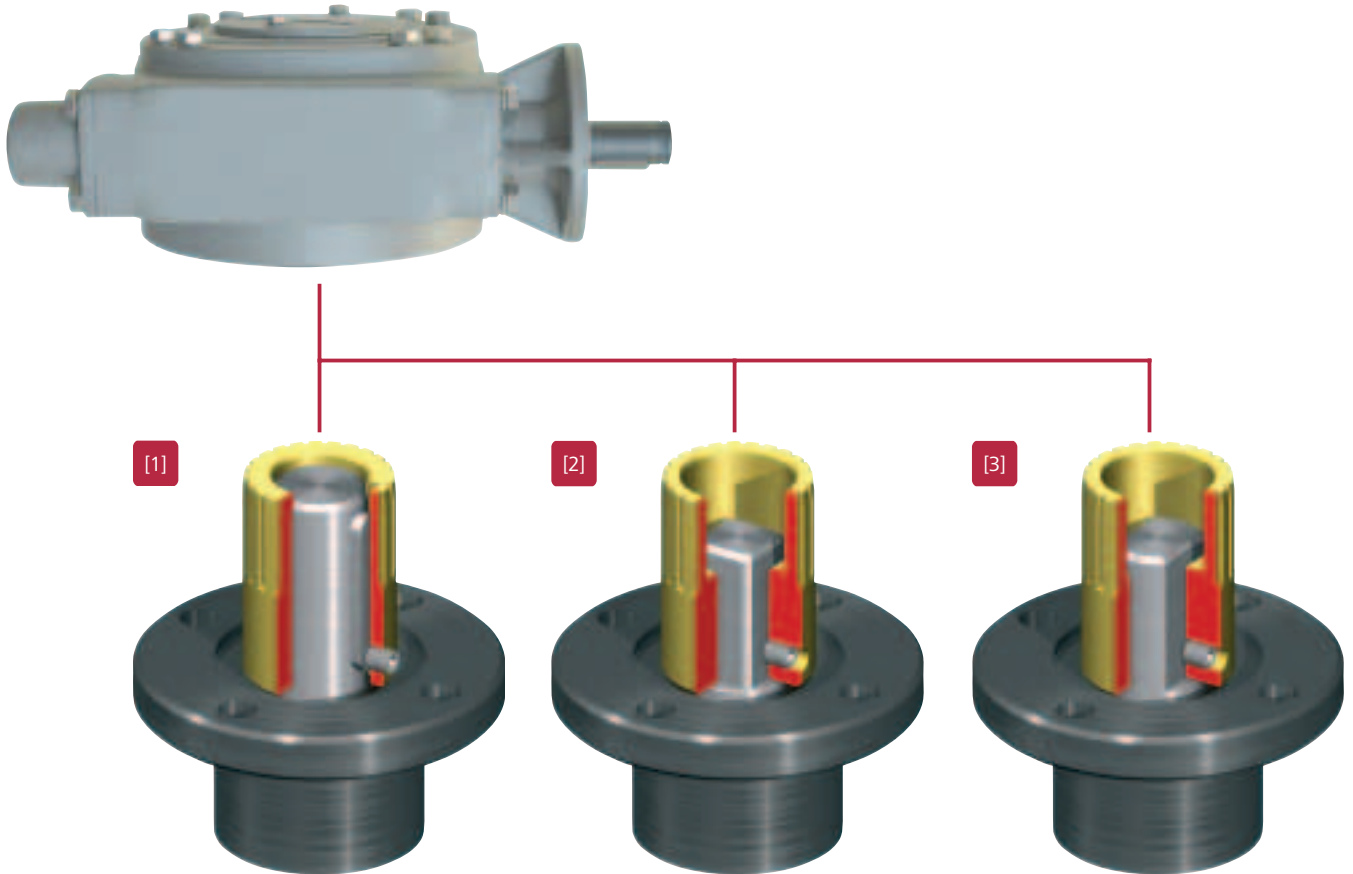

If the coupling is bored, it is supplied with a grub screw to fasten the coupling to the valve shaft.

[1] Bore with keyways

The bore according to EN ISO 5211 can be supplied with one, two, three or four keyways. The keyways conform to DIN 6885 P1. For keyways with other dimensions please contact AUMA.

[2] Square bore

according to EN ISO 5211 or with special diameter, please consult AUMA.

[3] Bore with two-flats

according to EN ISO 5211 or with special diameter, please consult AUMA.

Technical data

Torques

The following data applies to gearboxes with a worm wheel made of spheroidal cast iron. For data on gearboxes with a worm wheel made of bronze refer to separate technical data sheets.

Gearboxes	Output torques			Suitable primary reduction gearing	Input torques			Turns for 90°	Valve attachment
	100 % max [Nm]	140 % max [Nm]	200 % max [Nm]		for an output torque of				
					100 % Nm	140 % Nm	200 % Nm		EN ISO 5211
GS 50.3	250	350	500	–	15	21	30	12.75	F07 F10
GS 63.3	500	700	1,000	–	31	43	61	12.75	F10 F12
GS 80.3	1,000	1,400	2,000	–	55	77	110	13.25	F12 F14
GS 100.3	2,000	2,800	4,000	–	107	150	214	13	F14 F16
				VZ 2.3 2.4:1	47	65	93	31.5	
				VZ 3.3 3.1:1	38	52	74	40	
				VZ 4.3 4:1	28	40	57	52	
GS 125.3	4,000	5,600	8,000	–	208	292	417	13	F16 F25
				VZ 2.3 2.4:1	91	127	182	31.5	
				VZ 3.3 3.1:1	72	100	143	40	
				VZ 4.3 4:1	55	77	110	52	
	100 % max [Nm]	140 % max [Nm]	175 % max [Nm]		100 % Nm	140 % Nm	175 % Nm		
GS 160.3	8,000	11,250	14,000	–	381	536	667	13.5	F25 F30
				GZ 160.3 4:1	105	148	184	54.5	F25
				GZ 160.3 8:1	52	73	90	110.5	F30
GS 200.3	16,000	22,500	28,000	–	773	1,087	1,353	13.25	F30 F35
				GZ 200.3 4:1	213	300	373	53.5	F30
				GZ 200.38:1	105	148	184	108.5	F35
GS 250.3	32,000	45,000	56,000	–	1,576	2,217	2,759	13	F35 F40
				GZ 250.3 4:1	432	608	757	52.5	F35 F40
				GZ 250.3 8:1	222	313	389	103	
				GZ 250.3 16:1	122	171	213	212	
	100 % max [Nm]	140 % max [Nm]		for an output torque of					
				100 % Nm	140 % Nm				
GS 315	63,000	90,000	–	2,636	3,766	13.25	F40		
			GZ 30 8:1	389	556	106			
			GZ 30 16:1	194	277	212			
			GZ 30 32:1	97	138	424			
GS 400	125,000	180,000	–	5,144	7,407	13.5	F48		
			GZ 35 8:1	758	1,091	108			
			GZ 35 16:1	379	544	216			
GS 500	250,000	360,000	–	10,684	15,385	13	F60		
			GZ 40 16:1	786	1,132	208			
			GZ 40 32:1	393	566	416			
			GZ 40/GZ 16 64:1	218	314	832			

Possible combinations with multi-turn actuators (part-turn actuators)

The following data applies to gearboxes with a worm wheel made of spheroidal cast iron. For detailed data on gearboxes with a worm wheel made of bronze refer to separate technical data sheets.

Gearboxes	Primary reduction gearing	Suitable AUMA multi-turn actuator for 100 % output torque	Operating time range for 50 Hz in seconds for 90° swing angle ¹
GS 50.3	–	SA 07.1	17 – 192
GS 63.3	–	SA 07.5	17 – 192
GS 80.3	–	SA 07.5	18 – 199
GS 100.3	–	SA 10.1	17 – 195
	VZ 2.3	SA 07.5	21 – 472
	VZ 3.3	SA 07.5	19 – 600
	VZ 4.3	SA 07.5	17 – 780
GS 125.3	–	SA 14.1	17 – 195
	VZ 2.3	SA 10.1	21 – 472
	VZ 3.3	SA 10.1	19 – 600
	VZ 4.3	SA 07.5	17 – 780
GS 160.3	–	SA 14.5	18 – 203
	GZ 160.3 4:1	SA 10.1	18 – 818
	GZ 160.3 8:1	SA 07.5	37 – 829
GS 200.3	–	SA 16.1	18 – 199
	GZ 200.3 4:1	SA 14.1	18 – 803
	GZ 200.3 8:1	SA 10.1	36 – 814
	GZ 200.3 16:1	SA 07.5/SA 10.1	72 – 810
GS 250.3	–	SA 25.1	24 – 195
	GZ 250.3 4:1	SA 14.5	25 – 788
	GZ 250.3 8:1	SA 14.1	34 – 733
	GZ 250.3 16:1	SA 14.1	71 – 795
GS 315	–	SA 30.1	25 – 50
	GZ 30 8:1	SA 14.5	35 – 289
	GZ 30 16:1	SA 14.1	71 – 283
	GZ 30 32:1	SA 10.1	141 – 283
GS 400	–	SA 35.1	37 – 51
	GZ 35 8:1	SA 16.1	36 – 295
	GZ 35 16:1	SA 14.5	72 – 288
	GZ 35 32:1	SA 14.1	144 – 288
GS 500	–	SA 40.1	35 – 49
	GZ 40 16:1	SA 16.1	69 – 390
	GZ 40 32:1	SA 14.5	139 – 277
	GZ 40/GZ 16 64:1	SA 14.1	277 – 399

¹ Fixed operating times, where each operating time is 1.4 times longer than the previous

Lifetime

The following data applies to gearboxes with a worm wheel made of spheroidal cast iron. For detailed data on gearboxes with a worm wheel made of bronze refer to separate technical data sheets.

Gearboxes	Operating cycles (OPEN - CLOSE - OPEN) for swivel movements of 90° (max. 100°) and a maximum output torque of			
	100 %	140 %	175 %	200 %
GS 50.3	15,000	5,000	–	1,000
GS 63.3	15,000	5,000	–	1,000
GS 80.3	15,000	5,000	–	1,000
GS 100.3	15,000	5,000	–	1,000
GS 125.3	15,000	5,000	–	1,000
GS 160.3	15,000	5,000	1,000	–
GS 200.3	15,000	5,000	1,000	–
GS 250.3	10,000	3,000	750	–
GS 315	7,500	2,500	–	–
GS 400	4,000	1,200	–	–
GS 500	4,000	1,200	–	–

Certificates

EU Directives

Declaration of Incorporation in compliance with the Machinery Directive and Declaration of Conformity according to the ATEX, Low Voltage and EMC Directives

According to the Machinery Directive, AUMA actuators and actuator controls are considered as partly completed machinery. This means that a Declaration of Conformity in accordance with this Directive will not be issued by AUMA. AUMA's Declaration of Incorporation confirms that during the design stage of the devices, the fundamental safety requirements stipulated in the Machinery Directive were applied.

AUMA actuators fulfil the requirements of the ATEX, Low Voltage and EMC Directives. This has been proved in extensive tests. Therefore, AUMA issues a Declaration of Conformity.

The declarations of incorporation and conformity form a joint certificate, also integrated within the operation instructions.

According to the Low Voltage and EMC Directives, the devices are labelled with the CE mark.



Final inspection record

After assembly all gearboxes are thoroughly tested according to AUMA's inspection specification. The procedure is recorded on the final inspection record.

Where can I get the certificates?

All certificates and records are provided by AUMA on request either as a hard or digital copy.

The documents can be downloaded from the AUMA website around the clock; some of them are password protected.

- www.auma.com



At AUMA, everything revolves around the electric actuator. In a world where industrial processes have become increasingly complex, concentration is an asset – while still being able to see the bigger picture.

AUMA has to cope with a multitude of requirements from the most different applications and from every corner of the world - this is our daily business. We rise to this challenge by pursuing a clear but flexible product policy – supplying the ideal actuator to every customer.

For this purpose, you have to know your markets. Thinking globally means acting regionally. A comprehensive worldwide sales and service network ensures that there is a competent local contact for every customer.

Since 1964, AUMA has established an excellent brand name in the world of actuators. Reliability and innovation are concepts which are closely linked with AUMA. This is above all to be credited to AUMA's dedicated employees who work devotedly on the future of the actuator.



Quality is not just a matter of trust

Actuators must be reliable and dependable. They determine the steps of accurately defined work processes.

Reliability does not begin during commissioning. It begins with a well thought out design and careful selection of materials. This continues with conscientious production using highly sophisticated machinery in clearly controlled and supervised steps, while keeping in mind the environment.

The importance of environmentally sound production is reflected in our certifications according to ISO 9001 and ISO 14001. At AUMA, quality management is not considered as a single and static matter but is monitored on a daily basis. Numerous customer and independent audits confirm these high standards.



Literature

Further literature

Brochures

- Information
Electric actuators and valve gearboxes according to ATEX directive 94/9/EC for the use in potentially explosive atmospheres
- Information
Electric part-turn actuators SA/GS combinations

Technical data

- Worm gearbox and primary reduction gearing
Version with worm wheel made of bronze
GS 50.3 – GS 125.3/VZ
GS 160.3 – GS 250.3/GZ
 - Worm gearbox and primary reduction gearing
Version with worm wheel made of bronze
GS 315 – GS 500/GZ
 - Worm gearbox and primary reduction gearing
Version with worm wheel made of spheroidal cast iron
GS 50.3 – GS 125.3/VZ
GS 160.3 – GS 250.3/GZ
 - Worm gearbox and primary reduction gearing
Version with worm wheel made of spheroidal cast iron
GS 315 – GS 500/GZ
- Furthermore, there are dimension sheets available.



The latest issues of all documentation can be downloaded as PDF files from www.auma.com.

Index

A

Ambient temperature 8
Anti-backdrive device 12
ATEX directive 18

B

Buried service 8

C

CE mark 18
Certificates 18
Colour 9
Corrosion protection 9
Coupling 7

E

Enclosure protection IP 8
End stops 7
EU directives 18
Explosion protection 9

F

Feedback signals 13
Functional test 18

G

Gearboxes in multi-turn version 10

H

Housing 7

I

Indication 14

L

Lifetime 17
Literature 20

M

Manual operation 4
Modulating duty 4
Motor operation 4
Multi-turn actuator 7,17

O

Open-close duty 4
Overload protection 6,11

P

Painting 9
Part-turn actuator 5
Pointer cover 7
Position indication 14

R

Reduction gearing 5,7

S

Self-braking 12
Self-locking 12
Signals 13
Swing angle 10

T

Torques 16

V

Valve attachment 7,15
Valve end position 13 - 14
Valve position 13 - 14
Valve position indicator 13
Versions 5

Europe

AUMA Riester GmbH & Co. KG

Plant Müllheim
DE-79373 Müllheim
Tel +49 7631 809 - 0
riester@auma.com
www.auma.com

Plant Ostfildern-Nellingen
DE-73747 Ostfildern
Tel +49 711 34803 - 0
riester@wof.auma.com

Service Center Cologne
DE-50858 Köln
Tel +49 2234 2037 - 9000
Service@sck.auma.com
Service Center Magdeburg
DE-39167 Niederndodeleben
Tel +49 39204 759 - 0
Service@scm.auma.com
Service Center Bavaria
DE-85386 Eching
Tel +49 81 65 9017- 0
Riester@scb.auma.com

AUMA Armaturentriebe GmbH
AT-2512 Tribuswinkel
Tel +43 2252 82540
office@auma.at
www.auma.at

AUMA (Schweiz) AG
CH-8965 Berikon
Tel +41 566 400945
RettichP.ch@auma.com

AUMA Servopohony spol. s.r.o.
CZ-250 01 Brandýs n.L.-St.Boleslav
Tel +420 326 396 993
auma-s@auma.cz
www.auma.cz

OY AUMATOR AB
FI-02230 Espoo
Tel +358 9 5840 22
auma@aumator.fi
www.aumator.fi

AUMA France S.A.R.L.
FR-95157 Taverny Cedex
Tel +33 1 39327272
info@auma.fr
www.auma.fr

AUMA ACTUATORS Ltd.
GB- Clevedon North Somerset BS21 6TH
Tel +44 1275 871141
mail@auma.co.uk
www.auma.co.uk

AUMA ITALIANA S.r.l. a socio unico
IT-20023 Cerro Maggiore (MI)
Tel +39 0331 51351
info@auma.it
www.auma.it

AUMA BENELUX B.V.
NL-2314 XT Leiden
Tel +31 71 581 40 40
office@benelux.auma.com
www.auma.nl

AUMA Polska Sp. z o.o.
PL-41-219 Sosnowiec
Tel +48 32 783 52 00
biuro@auma.com.pl
www.auma.com.pl

OOO PRIWODY AUMA
RU-141400 Khimki, Moscow region
Tel +7 495 221 64 28
aumarussia@auma.ru
www.auma.ru

ERICHs ARMATUR AB
SE-20039 Malmö
Tel +46 40 311550
info@erichsarmatur.se
www.erichsarmatur.se

GRØNBECH & SØNNER A/S
DK-2450 København SV
Tel +45 33 26 63 00
GS@g-s.dk
www.g-s.dk

IBEROPLAN S.A.
ES-28027 Madrid
Tel +34 91 3717130
iberoplan@iberoplan.com

D. G. Bellos & Co. O.E.
GR-13673 Acharnai Athens
Tel +30 210 2409485
info@dgbellos.gr

SIGURD SØRUM A. S.
NO-1300 Sandvika
Tel +47 67572600
post@sigurd-sorum.no

INDUSTRA
PT-2710-297 Sintra
Tel +351 2 1910 95 00
industria@tyco-valves.com

MEGA Endüstri Kontrol Sistemleri Tic. Ltd. Sti.
TR-06810 Ankara
Tel +90 312 217 32 88
megaendustri@megaendustri.com.tr
www.megaendustri.com.tr

Africa

AUMA South Africa (Pty) Ltd.
ZA-1560 Springs
Tel +27 11 3632880
aumasa@mwweb.co.za

Solution Technique Contrôle Commande
DZ- Bir Mourad Rais Algiers
Tel +213 21 56 42 09/18
stcco@wissal.dz

A.T.E.C.
EG- Cairo
Tel +20 2 23599680 - 23590861
atec@intouch.com

America

AUMA Automação do Brazil Ltda.

BR- Sao Paulo

Tel +55 11 4612-3477
contato@auma-br.com

AUMA ACTUATORS INC.

US-PA 15317 Canonsburg

Tel +1 724-743-AUMA (2862)
mailbox@auma-usa.com
www.auma-usa.com

AUMA Chile Representative Office

CL-9500414 Buin

Tel +56 2 821 4108
aumachile@adsl.tie.cl

LOOP S. A.

AR-C1140ABP Buenos Aires

Tel +54 11 4307 2141
contacto@loopsa.com.ar

TROY-ONTOR Inc.

CA-L4N 8X1 Barrie Ontario

Tel +1 705 721-8246
troy-ontor@troy-ontor.ca

Ferrostaal de Colombia Ltda.

CO- Bogotá D.C.

Tel +57 1 401 1300
dorian.hernandez@ferrostaal.com
www.ferrostaal.com

PROCONTIC Procesos y Control Automático

EC- Quito

Tel +593 2 292 0431
info@procontic.com.ec

Corsusa International S.A.C.

PE- Miraflores - Lima

Tel +51 1444-1200 / 0044 / 2321
corsusa@corsusa.com
www.corsusa.com

PASSCO Inc.

PR-00936-4153 San Juan

Tel +1 787 620-8785
jgarcia@passcoinc.net

Suplibarca

VE- Maracaibo Estado, Zulia

Tel +58 261 7 555 667
suplibarca@intercable.net.ve

Asia

AUMA Actuators Middle East W.L.L.

BH-Salmabad 704

Tel + 97 3 17896585
Naveen.Shetty@auma.com

AUMA Actuators (Tianjin) Co., Ltd.

CN-300457 Tianjin

Tel +86 22 6625 1310
mailbox@auma-china.com
www.auma-china.com

AUMA (INDIA) PRIVATE LIMITED

IN-560 058 Bangalore

Tel +91 80 2839 4656
info@auma.co.in
www.auma.co.in

AUMA JAPAN Co., Ltd.

JP-210-0848 Kawasaki-ku,

Kawasaki-shi Kanagawa

Tel +81 44 329 1061
mailbox@auma.co.jp
www.auma.co.jp

AUMA ACTUATORS (Singapore) Pte Ltd.

SG-569551 Singapore

Tel +65 6 4818750
sales@auma.com.sg
www.auma.com.sg

Al Ayman Industrial. Eqpts

AE- Dubai

Tel +971 4 3682720
auma@emirates.net.ae

PERFECT CONTROLS Ltd.

HK- Tsuen Wan, Kowloon

Tel +852 2493 7726
joeip@perfectcontrols.com.hk

DW Controls Co., Ltd.

KR-153-702 Gasan-dong,

GeumChun-Gu, Seoul

Tel +82 2 2624 3400
import@actuatorbank.com
www.actuatorbank.com

Al-Arfaj Engineering Co WLL

KW-22004 Salmiyah

Tel +965-24817448
info@arfajengg.com
www.arfajengg.com

Petrogulf W.L.L

QA- Doha

Tel +974 4350 151
pgulf@qatar.net.qa

Sunny Valves and Intertrade Corp. Ltd.

TH-10120 Yannawa Bangkok

Tel +66 2 2400656
sunnyvalves@inet.co.th
www.sunnyvalves.co.th/

Top Advance Enterprises Ltd.

TW- Jhonghe City Taipei Hsien (235)

Tel +886 2 2225 1718
support@auma-taiwan.com.tw
www.auma-taiwan.com.tw

Australia

BARRON GJM Pty. Ltd.

AU-NSW 1570 Artarmon

Tel +61 294361088
info@barron.com.au
www.barron.com.au

[1] Multi-turn actuators
SA 07.2 – SA 16.2/SA 25.1 – SA 48.1
Torques from 10 to 32,000 Nm
Output speeds from 4 to 180 rpm

[2] Multi-turn actuators SA/SAR
with controls AUMATIC
Torques from 10 to 1,000 Nm
Output speeds from 4 to 180 rpm

[3] Linear actuators SA/LE
Combination of multi-turn actuator SA
with linear thrust unit LE
Thrusts from
4 kN to 217 kN
Strokes up to 500 mm
Linear speeds
from 20 to 360 mm/min

[4] Part-turn actuators
SG 05.1 – SG 12.1
Torques from 100 to 1,200 Nm
Operating times for 90° from 4 to 180 s

[5] Part-turn actuators SA/GS
Combination of multi-turn actuator SA with
part-turn gearbox GS
Torques up to 675,000 Nm

[6] Bevel gearboxes
GK 10.2 – GK 40.2
Torques up to 16,000 Nm

[7] Spur gearboxes
GST 10.1 – GST 40.1
Torques up to 16,000 Nm

[8] Worm gearboxes with base and lever
GF 50.3 – GF 250.3
Torques up to 32,000 Nm

AUMA Riester GmbH & Co. KG

P.O.Box 1362
D-79379 Muellheim
Tel +49 7631-809-0
Fax +49 7631-809-1250
riester@auma.com

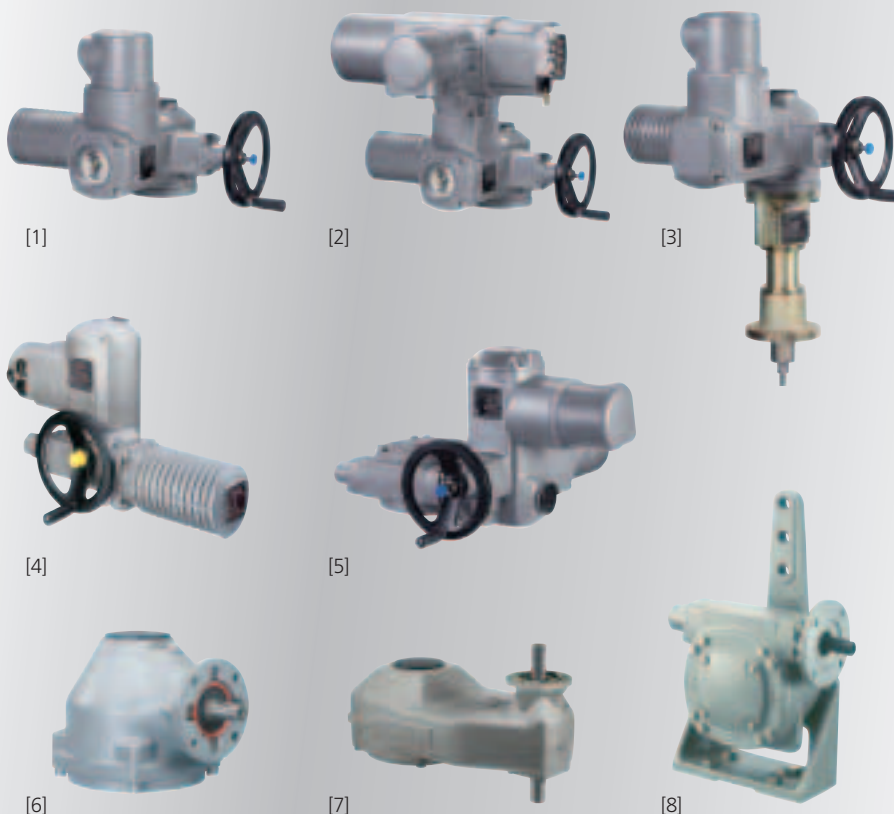

Subject to change without notice.
The product features and technical data provided do not express or imply any warranty.
Y000.337/003/en/1.10